

RMO-TT Series

Tap Changer Analyzer & Winding Ohmmeter



Amperis Products S.L.

Barbeito Maria 14, 27003, Lugo, Spain

T (+34) 982 20 99 20 | F (+34) 982 20 99 | info@amperis.com

amperis

RMO-TT Series

Tap Changer Analyzer & Winding Ohmmeter

- On-load tap changer dynamic resistance measurement
- Three resistance measurement channels
- Four temperature measurement channels
- Vibration measurement
- Automatic resistance/temperature measurement for the Heat Run test
- Rapid automatic demagnetization
- Tap changer motor current monitoring channel
- Automatic discharge circuit
- Three models: RMO40TT, RMO60TT, RMO100TT



Description

The Tap Changer Analyzer & Winding Ohmmeter of the RMO-TT series is designed for winding resistance measurement of inductive objects, and for a tap changer analysis. The RMO-TT series is based on the state of the art technology, using the most advanced switch mode technology available today. The RMO-TT instruments are accurate (0,1%), powerful (up to 100 A) and still portable. The Instruments generate a true DC ripple free current with automatically regulated measurement and discharging circuit.

RMO-TT instruments can perform a simple, quick and reliable transformer on-load tap changer condition assessment. This series of instruments enable measurements of a winding resistance in every tap position, current ripple values (percentage of a current drop during a tap change) and transition times during the tap changes. Problems with a connection, contacts, and selector/diverter switch operation (tap change with interruption) can be detected with these measurements.

Application

The list of the instrument application includes:

- Three-channel winding resistance measurement, which enables simultaneous winding resistance measurement of up to three windings on a single phase
- Dynamic resistance measurement (DVtest) of on-load tap changers, performed on a single phase
- A measurement of on-load tap changer motor current by using a dedicated channel
- Measurement of on-load tap changer external tank vibrations using an accelerometer
- Heat Run test, which enables obtaining the Hot Spot temperature along with temperature/resistance graph during the cooling process
- A single-phase automatic transformer demagnetization

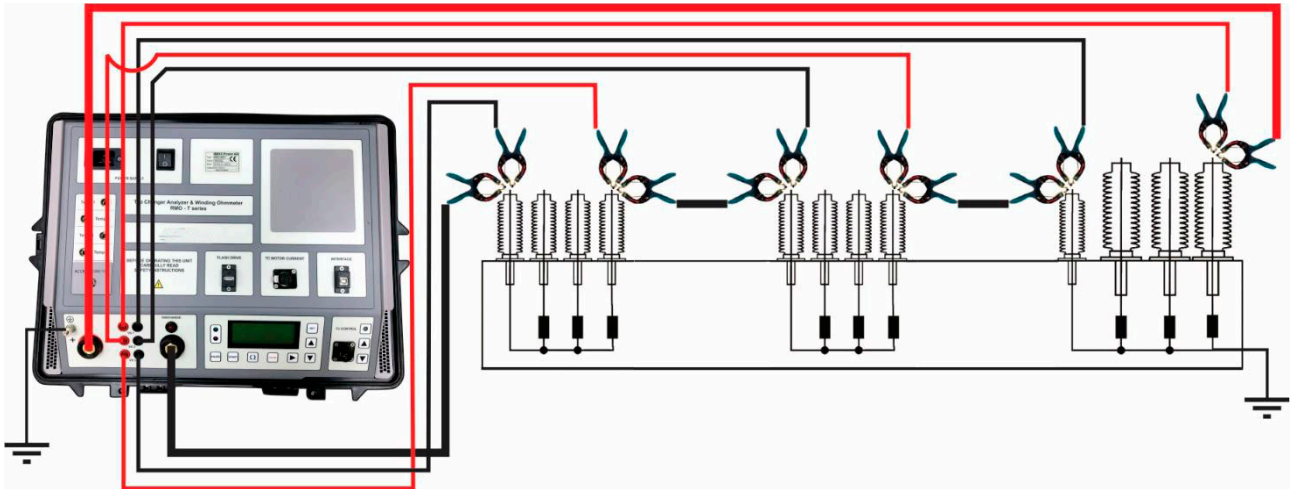

Connecting RMO-TT to a Transformer

The RMO-TT series has three separate resistance measurement channels, which enable simultaneous measurement of the primary, secondary and tertiary winding on the same phase. This significantly speeds up the measurement and reduces the total transformer testing time. At the same time, by saturating the magnetic core through the HV and LV windings the stabilization time and subsequently the total testing time is reduced even more.

Simultaneous Three-Channel Winding Resistance Measurement

The RMO-TT instruments inject the current with a voltage value as high as 55 V. This ensures that the magnetic core is saturated quickly and duration of the test is as short as possible. The three independent channels enable simultaneous testing of three windings in series – primary, secondary and tertiary windings, as presented in the figure above. There is enough memory within the RMO-TT instrument to store 1_000 measurements. All measurements are time and date stamped.

The instrument is equipped with thermal and overcurrent protection. The RMO-TT has very high ability to cancel electrostatic and electromagnetic interference that exists in HV electric fields. It is achieved by a proprietary filtration solution applied to both, the hardware construction and the application software implementation.

On Load Tap Changers – Dynamic Resistance Measurement (DV test)

The RMO-TT can be used to measure the winding resistance of the individual taps of a power transformer without discharging between the tests.

The unit also checks whether the on-load tap changer (OLTC) switches without an interruption. The moment a tap position is changed from one tap to another, the device detects a sudden, very short drop of the test current. These drops called “Ripple” should be consistent, where any drop out-of-line should be investigated. Tap changer malfunctions can be detected by analyzing the measurements of transition ripple, transition time, and visualizing DRM graphs. In addition, the tap changer motor current is recorded, and displayed on the same graph. The built-in tap changer control unit enables remote control of the tap changer operation from the instrument’s keyboard.

On Load Tap Changers – Vibration Testing

In addition to DVtest, the RMO-TT instruments can test the tap changer condition by measuring vibrations on an external tap changer tank. This non-intrusive test is performed using DV-Win PC software, and it enables detecting various mechanical problems and checking the timing of tap changer operation.

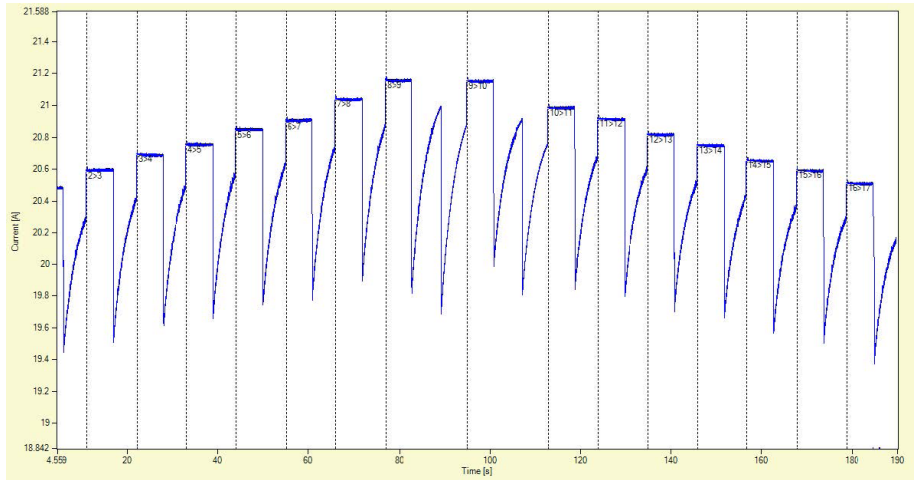

DV-Win Software

The DV-Win application software enables control and observation of the test process, as well as saving and analyzing the results on a PC. It provides a test report, arranged in a selectable form as an Excel spreadsheet, PDF, Word, or ASCII format. The software provides an OLTC (tap changer) condition assessment through analysis of the graphs representing dynamic resistance values during the tap changer transitions. Additionally, the DV-Win measures and calculates the OLTC transition time, the ripple and the winding resistance for each tap changing operation. The standard interface is USB. RS232 is optional.

Heat Run Test Application

The DV-Win application software has an additional Heat Run temperature/resistance extrapolation feature. After the transformer heating is switched off, the RMO-TT is immediately connected to up to three transformer windings and the timer is started. The winding resistance and temperature are measured at regular time intervals. This information is used to automatically extrapolate these values at the moment when the transformer was switched off.

Tap Changer Motor Current Monitoring Channel

The AC and/or DC current monitoring channel enables monitoring and recording the OLTC mechanical drive motor current during the tap changer operation. The

motor current waveform (or another useful signal) is printed on the same

DV-Win-generated DRM graph and can help in detecting OLTC mechanical problems. Motor recording allows for DRM recording by using the motor operation trigger, which is useful for reactance tap changers. An AC/DC current clamp is part of the recommended accessories.

Automatic Transformer Demagnetization

After a DC current test, such as a winding resistance measurement, the magnetic core of a power or a measurement transformer may be magnetized. Also, when disconnecting a transformer from a service, some amount of magnetic flux trapped in the core could be present.

The remnant magnetism can cause various problems such as erroneous measurements on a transformer, or an inrush current at start-up of a power transformer, or an incorrect operation of the protective relays due to the magnetized CT cores. To eliminate this source of potential problems, demagnetization should be performed. When the discharging process has been completed, the RMO-TT can perform fully automatic demagnetization.

Demagnetizing the magnetic core of a transformer requires alternating current applied with decreasing magnitude down to zero. The RMO-TT provides this alternating current by internally changing the polarity of a controlled DC current.

Technical data

Winding Resistance Measurement

- Test currents:
 - 5 mA – 40 A DC for RMO40TT
 - 5 mA – 60 A DC for RMO60TT
 - 5 mA – 100 A DC for RMO100TT
- Output voltage: up to 55 V DC
- Measurement range: 0,1 $\mu\Omega$ - 100 k Ω
- Typical accuracy
 - \pm (0,1 % rdg + 0,1 % FS) for 0,1 $\mu\Omega$ – 1,999 k Ω range
 - \pm (0,2 % rdg + 0,1 % FS) for 2,000k Ω – 9,999 k Ω range

Resolution

- 0,1 $\mu\Omega$ – 999,9 $\mu\Omega$: 0,1 $\mu\Omega$
- 1,000 m Ω – 9,999 m Ω : 1 $\mu\Omega$
- 10,00 m Ω – 99,99 m Ω : 10 $\mu\Omega$
- 100,0 m Ω – 999,9 m Ω : 0,1 m Ω
- 1,000 Ω – 9,999 Ω : 1 m Ω
- 10,00 Ω – 99,99 Ω : 10 m Ω
- 100,0 Ω – 999,9 Ω : 0,1 Ω
- 1 000 Ω – 9 999 Ω : 1 Ω

Data Storage

- 1000 internal memory positions
- USB flash drive feature enables storage of a huge number of measurements

Printer (optional)

- Thermal printer
- Paper width 80 mm

OLTC Dynamic Resistance Measurement

- Sampling rate: 0,1 ms
- Automatic open circuit detection and warning
- Transition current ripple measurement
- Transition time measurement using DV-Win software
- Timing measurement of different transition changes using DV-Win graph analysis tool

AC Current Measurement Channel

- Resolution: 0,1 ms
- Amplitude resolution: 16 bit

Current Clamp Meter Specifications

- Measuring range: 30 / 300 A

- Nominal current: 300 A_{RMS} or 450 A DC_{PK}
- Frequency range: DC to 20 kHz (-3 dB)

Computer Interface

- USB
- Optional: RS232

Warranty

- Three years

Environmental Conditions

- Operating temperature:
 - 10 °C - +55 °C / 14 °F - +131 °F
- Storage & transportation:
 - 40 °C - +70°C / -40 °F - +158 °F
- Humidity 5 % - 95 % relative humidity, non-condensing

Dimensions and Weight

Device	Weight	Dimensions (WxHxD)
RMO40TT RMO60TT	13,5 kg / 28.6 lbs	480 x 197 x 395 mm 18.9 x 7.8 x 15.6 in
RMO100TT	15,5 kg / 34,2 lbs	550 x 215 x 420 mm 21.6 x 8.5 x 16.5 in

Vibration Measurement Channel

- Resolution: 0,1 ms
- ICP accelerometer, \pm 100 mV/g, \pm 50 g

Temperature Measurement

- Four temperature measurement channels

Mains Power Supply

- Connection according to IEC/EN60320-1; UL498, CSA 22.2
- Mains supply: 90 V - 264 V AC
- Frequency: 50 / 60 Hz
- Mains supply voltage fluctuations up to \pm 10 % of the nominal voltage
- Input power: 2 250 VA
- Fuse 15 A / 250 V, type F, not user replaceable

Applicable Standards

- Installation/overvoltage: category II
- Pollution: degree 2
- Low voltage directive:
Directive 2014/35/EU (CE Conform)
Applicable standards, for a class I instrument, pollution degree 2, installation category II : IEC EN 61010-1
- Electromagnetic compatibility:
Directive 2014/30/EU (CE Conform)
Applicable standard EN 61326-1
- CAN/CSA-C22.2 No. 61010-1, 2nd edition, including Amendment 1

All specifications herein are valid at ambient temperature of + 25 °C and recommended accessories. Specifications are subject to change without notice. Specifications are valid if the instrument is used with the recommended set of accessories.

Accessories



Current cables with battery clamps



Voltage Sense cables with TTA clamps



Current connection cable



Current clamp 30/300 A with extension 5 m (16.4 ft)



Temperature probes 4 x 50 mm (1.97 in) + 5 m (16.4 ft) cable set



Test shunt



Cable plastic case



Cable plastic case with wheels



Accelerometer for vibration testing

Order info

Instrument with included accessories	Article No.
Tap Changer Analyzers& Winding Ohmmeters RMO-TT	RMOXTT-N-01
DV-Win PC software including USB cable	
Built-in Tap Changer Control Unit + Control cable 5 m (16.4 ft)	
Mains Power cable	
Ground (PE) cable	
Transport case	

Recommend	Article No.
Current cables 2 x 10 m 16 mm ² (32.8 ft, 5 AWG) with battery clamps*	C2-10-16LMB1
Current cables 2 x 10 m 10 mm ² (32.8 ft, 7 AWG) and Sense cables 2 x 10 m (32.8 ft) with TTA clamps**	CS-10-10LMWC
Sense cables 3*/2** x 2 x 10 m (32.8 ft) with TTA clamps*	S2-10-02BPWC
Current connection cable 2 x 5 m 16 mm ² (16.4 ft, 5 AWG) with battery clamps*	CX-05-162XB1
Current connection cable 2 x 5 m 10 mm ² (16.4 ft, 7 AWG) with TTA clamps**	CX-05-102XWC
Cable plastic case – large*/medium** size	CABLE-CAS-XX
Current clamp 30/300 A power supplied from the instrument with extension 5 m (16.4 ft)	CACL-0300-06

*Recommended for RMO100TT

**Recommended for RMO40TT and RMO60TT models

Optional	Article No.
Test shunt 150 A / 150 mV	SHUNT-150-MK
Thermal printer 80 mm (3.15 in) (built-in)	PRINT-080-00
Thermal paper roll 80 mm (3.15 in)	PRINT-080-RO
Cable plastic case – large/medium size (wheels optional)	CABLE-CAS-XX
Cable bag	CABLE-BAG-00
Temperature sensors 4 x 50 mm (1.97 in) + 5/10/15 m (16.4/32.8/49.2 ft) cable set	TEMP4-050-XX
Current cables 2 x 5/15 m 16/25 mm ² (16.4/49.2 ft, 5/3 AWG) with battery clamps	C2-XX-XXLMB1
Current cables 2 x 15 m 10 mm ² (49.2 ft, 7 AWG) and Sense cables 2 x 15 m (49.2.8 ft) with TTA clamps	CS-15-10LMXC
Current cables 2 x 20 m 35 mm ² (65.6 ft, 2 AWG) with battery clamps	C2-20-35LMB1
Sense cables 2 x 5/15/20 m (16.4/49.2/65.6 ft) with TTA clamps	S2-XX-02BPWC
ICP Accelerometer with 5/10/15 m connecting cable and mounting tools	ICP0-100-0XX
Current connection cable 1 x 12 m 16 mm ² (39.4 ft, 5 AWG) with battery clamps	CX-12-162XB1
Bluetooth communication module	BLUET-MOD-01

Amperis Products S.L.

Barbeito Maria 14, 27003, Lugo, Spain
T (+34) 982 20 99 20 | F (+34) 982 20 99
info@amperis.com



www.amperis.com

PROYECTO COFINANCIADO POR EL IGAPE, XUNTA DE GALICIA Y FONDO EUROPEO DE DESARROLLO REGIONAL DEL PROGRAMA OPERATIVO 2014-2020



Xacobeo 2021

